



AGENDA

Zoning Board of Appeals – Regular Meeting
Tuesday, June 27th, 2023 – 7:00 p.m.

- I. Call to Order
- II. Roll Call
- III. Approval of the April 25th, 2023 ZBA Meeting Minutes
- IV. Public Comments & Questions (*Agenda Items Only*)
- V. New Business
 - A. ZBA Variance Application No. 23-01 – Rust – Dimensional Variance (Walls, Deck)
 - B. ZBA Variance Application No. 23-02 – Griffeth - Dimensional Variance (Deck)
- VI. Old Business
 - A. ZBA Variance Application No. 22-01 – Westra – Permit Extension
- VII. Reports
- VIII. Extended Public Comments & Questions (*Non-Agenda Items*)
- IX. Adjournment

MEETING MINUTES
GRAND HAVEN CHARTER TOWNSHIP
ZONING BOARD OF APPEALS
APRIL 25, 2023

I. CALL TO ORDER

The regular meeting of the Grand Haven Charter Township Zoning Board of Appeals was called to order at 7:00 p.m. by Chair Voss.

II. ROLL CALL

Board of Appeals members present: Voss, Loftis, Behm, Slater, Hesselsweet, alt. Egedy-Bader
Board of Appeals members absent: None

Also present: Senior Planner Thibault,

Without objection, Thibault was instructed to record the minutes for the meeting.

III. APPROVAL OF MINUTES

Without objection, the minutes of the September 27, 2022 ZBA Meeting were approved.

IV. NEW BUSINESS

A. ZBA Variance Application No. 22-10 – Zamiara – Dimensional Variance

Party Requesting Variance: Nancy Zamiara
Address: 17461 Lakeside Trail
Parcel Number: 70-07-33-125-036
Location: 17461 Lakeside Trail

The applicant is seeking a variance to construct three new retaining wall systems, herein referred to as A, B, and C. System A would result in a 10’ height where a maximum height of 8’ is permitted; 1’ side yard setback where 10’ is required. System B would result in a 4’ side yard setback where 10’ is required. System C would result in a 7’ side yard setback where 10’ is required. The retaining walls violate Section 14.13.C of the Zoning Ordinance.

Thibault provided an overview through a memorandum dated April 20th.

The applicant, Ms. Zamiara, and her contractor Bill Monhollon were present to provide additional information

- Stated that a lot of the information was covered in the memo and had not significantly changed since the original application.

- Clarified that the proposed retaining wall for the driveway extension was located and sized in such a way as to provide an efficient and easy turning radius for vehicles to back-up and exit.
- Described how the retaining wall would step-back more than the vertical wall illustrated because the stacked wall will use modular blocks.
- Discussed how the new septic system would be constructed and accessed and where the drain field is located
- Stated the neighbors have been receptive of the proposed project

The Board discussed the application and noted the following:

- Questioned how runoff would be handled with the new drive and retaining wall
- Inquired if the extent of the driveway expansion as shown was necessary and how the septic tanks would be accessed
 - Staff stated what the regulations state for retaining wall setbacks, when engineered drawings need to be provided, and how wall setbacks are determined in the case of a stepped or stacked retaining wall
- Opined that a shared retaining wall with the neighbors to the South would be better than each property owner having individual retaining walls
 - Staff clarified that individual walls minimize the impacted area and avoid issues of shared maintenance

Standard No. 1 – Exceptional or extraordinary circumstances:

- The property is a legal lot of record and is non-conforming in lot width. The property is encumbered by both Critical Dune Area and regulated wetlands.

Ayes: Voss, Slater, Behm, Loftis, Hesselsweet

Nays: None

Absent: None

Standard No. 2 – Substantial property right:

- A series of retaining walls are required to maintain appropriate grading to provide a compliant building height for the addition and flat surface for a parking area.

Ayes: Voss, Slater, Behm, Loftis, Hesselsweet

Nays: None

Absent: None

Standard No. 3 – Will not be a substantial detriment to adjacent parcels, or material impact on the intent and purpose of the Ordinance:

- No correspondence had been received as of the original public hearing deadline of September 22nd nor in the interim.

Ayes: Voss, Slater, Behm, Loftis, Hesselsweet
Nays: None
Absent: None

Standard No. 4 – Request is not of such a recurrent nature as to make reasonably practical the formulation of a general regulation:

- Retaining wall: the limitations on the property due to the Critical Dune Area, regulated wetlands, and existing topography limit the buildable area and are unique to the property. The walls are needed in order to comply with the maximum building height and story requirement.

Ayes: Voss, Slater, Behm, Loftis, Hesselsweet
Nays: None
Absent: None

Motion by Slater, supported by Loftis, to **approve** a dimensional variance from Section 14.13.C of the Zoning Ordinance to construct a series of retaining walls at 17461 Lakeside Trail. This will result in three retaining wall systems: System A – has a 10-foot height and a 1-foot side yard setback . System B – Has a 4-foot side yard setback. System C – Has a 7-foot side yard setback. Approval of this variance is based upon this Board’s findings that all four standards have been affirmatively met.

Which motion carried unanimously, as indicated by the following roll call vote:

Ayes: Voss, Slater, Behm, Loftis, Hesselsweet
Nays: None
Absent: None

- V. REPORTS - None
- VI. EXTENDED PUBLIC COMMENTS – None
- VII. ADJOURNMENT

Without objection, the meeting was adjourned at 7:28 pm.

Respectfully submitted,



Rory Thibault
Acting Recording Secretary



GRAND HAVEN CHARTER TOWNSHIP

Community Development Memo

DATE: June 21, 2023

TO: Zoning Board of Appeals

FROM: Cassandra Chaphalkar – Associate Planner
Rory Thibault – Senior Planner

RE: 18165 Shore Acres Rd – Dimensional Variance Application No. 23-02

PROPERTY INFORMATION	
Owner	Dale & Mary Jo Rust
Property Address	18165 Shore Acres Rd
Parcel Number	70-03-32-331-017
Lot Size	21,350 sqft (.49 ac)
Lot Type	Legal Lot of Record
	Irregular Lot Shape
	Critical Dunes
Elevation	≈ 55 foot elevation change
Zoning	R-1 Single Family Residential
Required Setbacks for an Attached Deck	Front – 30% of the required front yard setback (35 feet)
	Rear – 40% of the required rear yard setback (20 feet minimum)
	Side – 15 feet each
Required Setbacks for Retaining Wall System Exceeding 4 ft in Height	Front – 30% of the required front yard setback (35 feet)
	Rear – 50 feet
	Side – 15 feet each
Maximum Height for a Retaining Wall	8 ft, either as a single wall or wall series
Required Setbacks for Retaining Wall 2 ft to 4 ft in Height	2 ft from any property line

PRIOR ZBA APPROVAL

Recall the dimensional variance application from November 2019, which was approved. A building permit was applied for in 2020 and issued in 2021, but the prior contractor was not able to perform the construction. Due to a lack of progress, the building permit expired. Because the variance approval is contingent on construction occurring, **the prior variance approval has expired.**



Site Location

Now, the property owner has found a new contractor to perform the work and is requesting the ZBA review and approve the variance request. **There are no changes in items or location from the previously approved variance.** The applicant has noted that the material of one retaining wall had changed, resulting in all retaining walls being constructed from sheet pile. The applicant's EGLE permit was previously issued and is still valid until October 2024.

VARIANCE ITEMS

There are two proposed retaining walls and a deck that are allowed to extend into the abutting trust property (*the paper walkway*) to the west of the property. No work is proposed to extend into the adjacent property, all construction will remain within the Rust property and the paper walkway. Recall, the Township has historically allowed this type of work to occur within the paper easements when a letter from the Homeowners Association was provided granting permission. Such a letter was received from the HOA Board in 2018 and reaffirmed in June, 2023.

There are five items identified as needing a variance:

- 1) A sheet pile retaining wall located north of the house measuring 2.9' in height would be built to the side lot line, resulting in a 0' side yard 1 setback where 2' is required.
 - a) Variance of 2'.

- 2) A series of sheet pile retaining walls located to the east of the house measuring 11' in height when 8' is permitted and having 14' side yard 2 setback where 15' is required.
 - a) Height variance of 3'.
 - b) Side yard setback variance of 1'.

- 3) A sheet pile retaining wall located south of the house measuring 5.8' in height located 31' from the front lot line where 50' is required and built to the side lot line, resulting in a 0' side yard setback where 15' is required.
 - a) Front yard variance of 19'.
 - b) Side yard setback of 15'.

- 4) A deck located on the west side of the house built to the side lot line, resulting in a 0' side yard setback where 15' is required. This will replace an existing deck in the same location and footprint.
 - a) Side yard setback of 15'.

- 5) A deck located on the east side of the house to have a 14' side yard setback where 15 is required. This will replace an existing concrete patio in the same location and footprint.
 - a) Side yard setback variance of 1'.

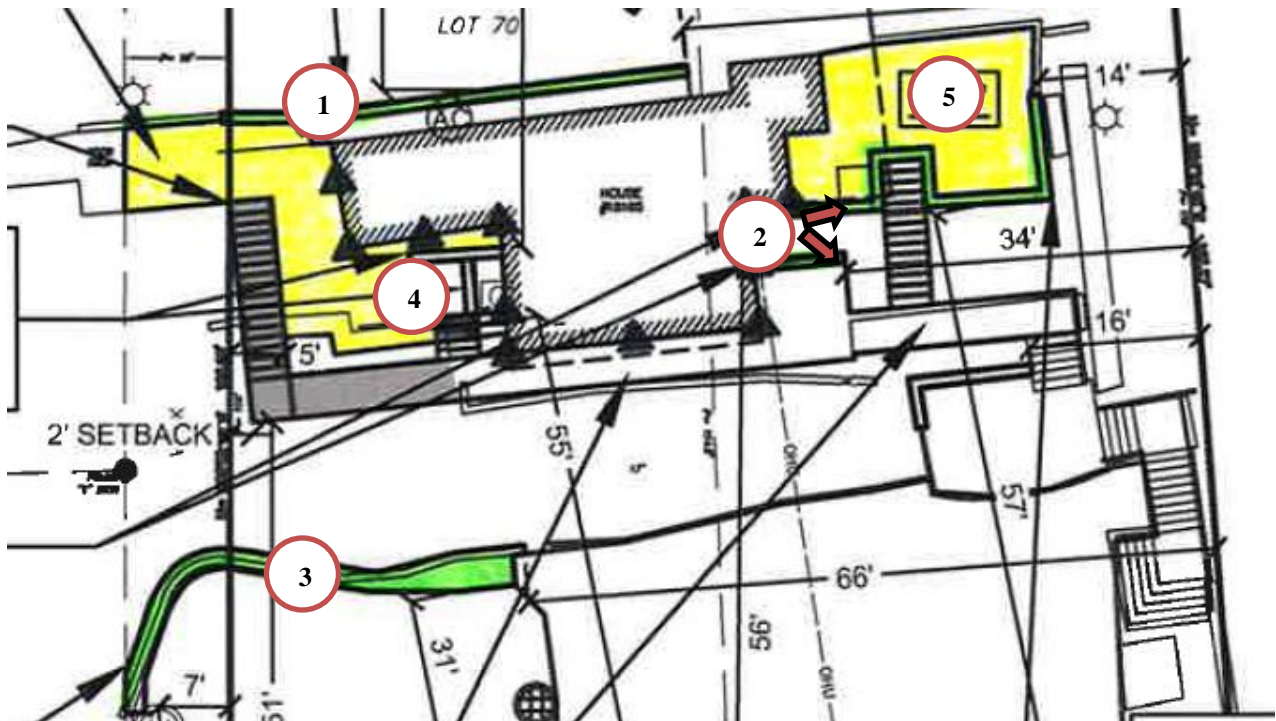

VARIANCE STANDARDS

To authorize a dimensional variance from the strict applications of the provisions of this Ordinance, the ZBA shall apply the following standards and make an affirmative finding as to each of the matters set forth in the standards.

STANDARD 1

There are exceptional or extraordinary circumstances or conditions applying to the property that do not apply generally to other properties in the same zoning classification.

The property is located within the Critical Dune Area and is encumbered by steep topographic changes (≈ 55 ft elevation change). The ZBA will need to determine as to whether this standard is met.

STANDARD 2

The variance is necessary for the preservation and enjoyment of a substantial property right similar to that possessed by other properties in the same zoning district and in the vicinity, provided that possible increased financial return shall not of itself, be deemed sufficient to warrant a variance.

The majority of homes along Lake Michigan have a series of decks that provide views. The retaining walls are needed to preserve and stabilize the aging house. The ZBA will need to make a determination as to whether this standard is met given the circumstances of this case.

STANDARD 3

Authorization of such variance will not be of substantial detriment to adjacent property, and will not materially impair the intent and purpose of this Ordinance or the public health, safety, and general welfare of the community.

No correspondence was received for this application . The ZBA will need to make the determination as to whether this standard is met given the circumstances of this case and the findings on standards 1 and 2.

STANDARD 4

The condition or situation of the specific piece of property or the intended use of said property for which the variance is sought, is not of so general or recurrent a nature as to make reasonably practical the formulation of a general regulation for such condition or situation, a part of this Ordinance.

There are many houses in the Township that are legally non-conforming in location. The steep topographic changes and legally non-conforming location of the house create the need for the retaining walls in order to preserve the owners' investment in their property. The ZBA will need to make the determination as to whether this standard is met.

SAMPLE MOTIONS

If the ZBA determines each standard has been affirmatively met, the following motion can be offered:

Motion to approve a dimensional variance from Sections 14.13.C, 14.13.C.2, and 14.13.C.3 and 10.04.C.4 of the Zoning Ordinance to construct a series of retaining walls and decks. The details are as follows:

1. Dimensional variance from Section 14.13.C.2 to allow a 4' tall retaining wall to be built to the property line that will result in setback variance of 2'.
2. Dimensional variance from Section 14.13.C.3 to allow a series of retaining walls totaling 11' in height that will result in a height variance of 3' and a side yard setback variance of 1'.
3. Dimensional variance from Section 14.13.C.3 to allow a retaining wall (not to exceed 8' in height) to be built to the property line that will result in a front yard setback variance of 19' and a side yard setback variance of 15'.
4. Dimensional variance from Section 10.04.C.4 to allow a deck to be built to the property line that will result in a side yard 1 setback variance of 15'.
5. Dimensional variance from Section 10.04.C.4 to allow a deck that will result in a side yard setback variance of 1'.

Approval of this variance is based upon this Board's findings that all four standards have been affirmatively met.

However, if the ZBA determines each standard as not been affirmatively met, the following motion can be offered:

Motion to deny a dimensional variance from Sections 14.13.C, 14.13.C.2, and 14.13.C.3 and 10.04.C.4 of the Zoning Ordinance to construct a series of retaining walls and decks. Denial of this variance is based upon this Board's findings that all four standards have not been affirmatively met. Further, staff is directed to draft a formal motion and report with those discussion points which will be reflected in the meeting minutes. This will be reviewed and considered for adoption at the next meeting.

If the ZBA determines that more information is needed to make an affirmative finding, the following motion can be offered:

Motion to postpone the dimensional variance application for 18165 Shore Acres Road pending the information below: *List items*.

Please contact me with questions or concerns

ADDENDUM to Zoning Board of Appeals Application: May 2023

Reference Permit #P19ZBA0002

Dated 11/26/2016

All previously submitted supporting documents have "Landtech" as the contractor and the new contractor of record is Hamstra Builders and should be noted as such.

Since Landtech is no longer involved, King Company of Holland Michigan will be installing the retaining walls and all will be sheet pile similar to what is currently installed at the property.

Dale and Mary Jo Rust
1939 Koehling Road
Northbrook, IL 60062

November 30, 2018

The Board has reviewed your requests for several private use structural changes and additions to the Trust Property that follows the West side of your property in Shore Acres Association, Cottage #28 as you are preparing your stabilization project. First, we will repeat our acknowledgement from our email of October 6, 2018 that your well, driveway and retaining wall exists on Trust Property. These structures were in place when you purchased the property. We stated then that we have no objection to the re-do of the retaining wall in the same location as it is now. You have also asked us to approve the building of a stair structure on the Trust Property from your proposed "boardwalk" on the South side of your home, up the dune on Trust Property (drawing attached). We have no objection to the stairs as long as it does not cut off trafficking over the Trust Property by other Association members. We also have no objection to the placement of a dry well or rain water vault to be placed on the Trust Property, again as long as properly installed and maintained and does not impede trafficking over the Trust Property. This letter being signed by both of you will acknowledge that you will modify or remove any of the private structures on Trust Property at your expense if required by the Board to allow for pedestrian traffic as required in the Court's 1956 Order.

We ask that you provide us a copy of your MDEQ permit and any further building plans for our files.

This letter represents the position of the Shore Acres Board of Directors.

Bob DeBoer, President
Shore Acres Association

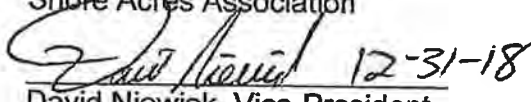
 12-31-18
David Niewiek, Vice-President
Shore Acres Association

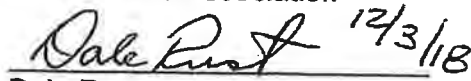
 12/3/18
Dale Rust
Cottage #28
Shore Acres Association

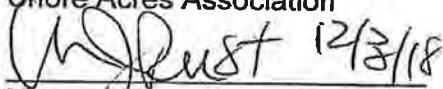
 12/3/18
Mary Jo Rust
Cottage #28
Shore Acres Association

Re: Letter of Non-Objection

From: David Niewiek (niewijk@msn.com)
To: sandrajeters7@gmail.com; drust.shoreacres@gmail.com
Cc: mcrdevelopment@hotmail.com; jennbrown.m@gmail.com
Date: Wednesday, June 7, 2023 at 07:11 PM CDT

Dale,

Let this email response be considered a "renewal" of the board's position of December, 1998. Our position has not changed.

Good luck on your project!

David Niewiek

Board,

Get [Outlook for IOS](#)

From: drust.shoreacres@gmail.com <drust.shoreacres@gmail.com>
Sent: Sunday, June 4, 2023 4:44:42 PM
To: David Niewiek <niewijk@msn.com>; Sandra Peters <sandrajeters7@gmail.com>
Subject: Letter of Non-Objection

David & Sandra

I am needing to re-apply for my Zoning Variance which included the letter from the Shore Acres board of directors dated November 30, 2018. (see attached)

They are asking if it is still in effect and if so they want confirmation. I'm assuming just an email to me would suffice. I am needing this response ASAP as I will be on the June ZBA schedule.

Thanks

Dale

<scan_20230604153226.pdf>

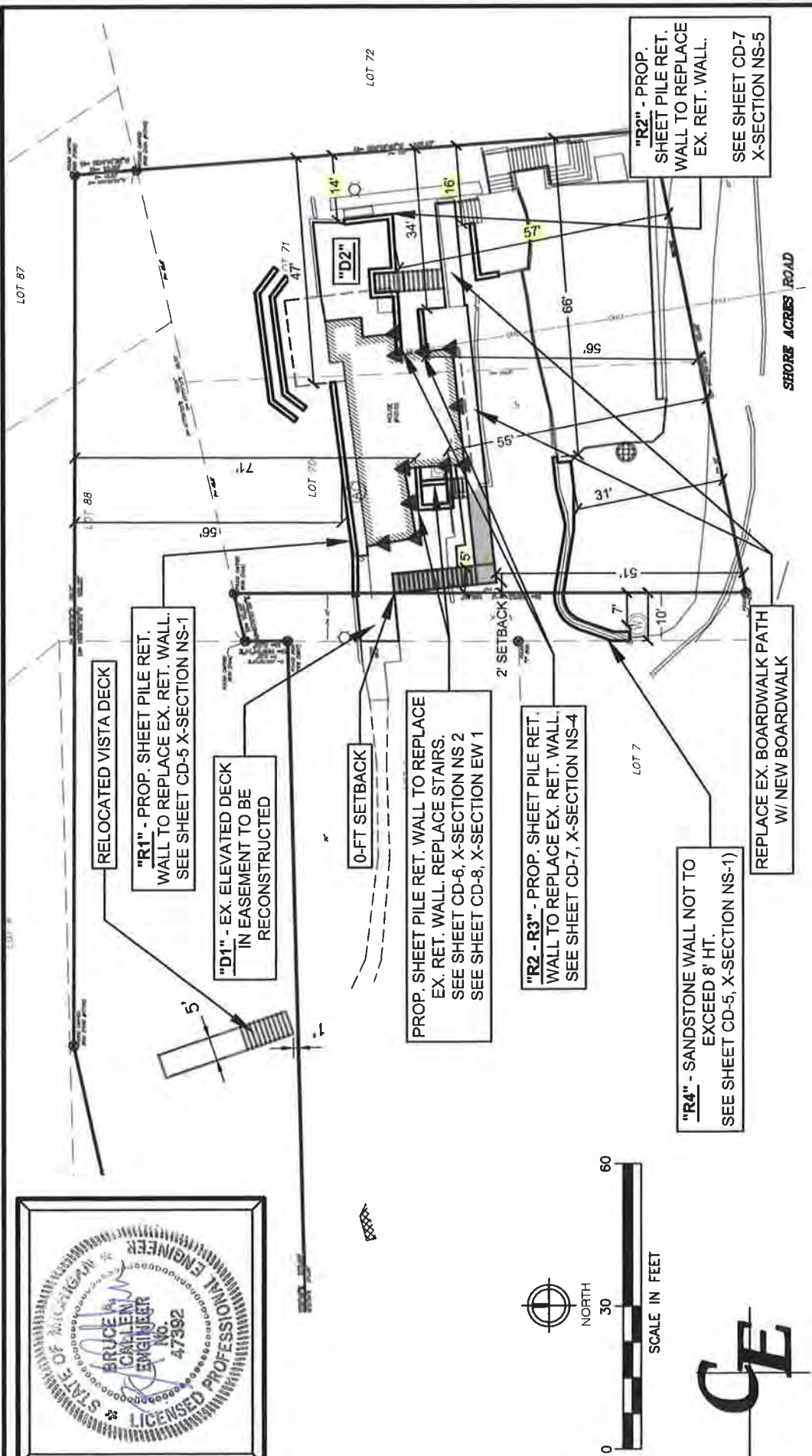

△ = APPROXIMATE HELICAL PIER LOCATION

SHEET
CD-2
 SITE PLAN

DATE OF PLAN: 11-04-19

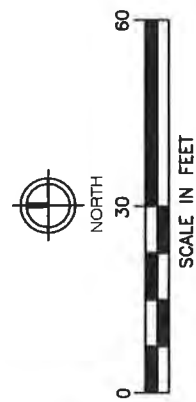

Callen Engineering, Inc.
 Spring Lake, Michigan

BRUCE A. CALLEN, P.E.

I CERTIFY THAT THE PROPOSED IMPROVEMENTS ARE NOT LIKELY TO INCREASE EROSION OR DECREASE STABILITY.



Permit

Soil Erosion & Sedimentation Control Agency

County of Ottawa

Issued under the authority of Part 91, Soil Erosion and Sedimentation Control, of the Natural Resources and Environmental Protection Act, 1994 PA 451, as amended

Permittee: Rust, Dale
Address: 1939 Koehling Rd
Northbrook, IL 60062

Permit No:	11576
Issued:	10/05/2018
Expires:	06/01/2021

Project Location: City/Village/Township: Grand Haven **Section:** 32

Address/Property Location: 18165 Shore Acres Rd

On-Site Responsible Person: Curt Hall

Company: Landtech

Telephone Number: 616-836-2286

Permitted Activity:

Excavate for New Deck, Retaining Wall, & Site Improvement Construction

Permit Conditions:

1. The permitted activity shall be completed in accordance with the approved plans and specifications, and the attached general and specific conditions.
2. This permit does not waive the necessity for obtaining all other required federal, state or local permits.
3. Permittee shall notify the permitting agency before the start of and within one week after completing the permitted activity or one week prior to the permit expiration date, whichever comes first. (616) 994-4528.

4. PERMITTEE IS RESPONSIBLE FOR PROVIDING A COPY OF PERMIT, APPROVED SESC PLAN, AND ALL RELATED INFORMATION TO THE CONTRACTOR AND ENGINEER.

Jon Braxmaier
Erosion Control Agent
Water Resources Commissioners Office
616-994-4528

**THIS PERMIT MUST BE POSTED
AT THE PROJECT SITE**



**MICHIGAN DEPARTMENT OF ENVIRONMENT, GREAT LAKES, AND ENERGY
WATER RESOURCES DIVISION
PERMIT**

Issued To:

**Dale Rust
1939 Koehling Road
Northbrook, IL 60062**

**Permit No: WRP015771 v.1
Submission No.: HNJ-6EA2-HTWYN
Site Name: 70-18165 Shore Acres Rd-Grand Haven
Issued: October 2, 2019
Revised:
Expires: October 2, 2024**

This permit is being issued by the Michigan Department of Environment, Great Lakes, and Energy (EGLE), Water Resources Division, under the provisions of the Natural Resources and Environmental Protection Act, 1994 PA 451, as amended (NREPA); specifically:

- | | |
|--|---|
| <input type="checkbox"/> Part 301, Inland Lakes and Streams | <input type="checkbox"/> Part 323, Shorelands Protection and Management |
| <input type="checkbox"/> Part 315, Dam Safety | <input checked="" type="checkbox"/> Part 353, Sand Dunes Protection and Management |

Permission is hereby granted, based on permittee assurance of adherence to State of Michigan requirements and permit conditions, to:

Authorized Activity:

This permit is issued as a Special Exception to Part 353 as this project impacts slopes greater than 1 on 3.

Remove 3 trees; install 11 helical piers underneath the existing house; construct two new, retaining walls, R-2 measuring 24 linear feet and R-3 measuring 18 linear feet; construct four replacement retaining walls, R-1 measuring 36 linear feet, R-4 measuring 39 linear feet, R-5 measuring 62 linear feet, and R-6 measuring 47 linear feet; remove the existing patio and construct a 408 square foot deck D-1 on pilings in its place; remove and replace existing decks D-2 and D-3, boardwalks and stairs only within the footprints of Lot 5 and 70 and the identified easement; remove existing deck D-4 and reconstruct it in place with an 150 square foot cantilevered expansion; install a dry well in the parking area and run approximately 35 linear feet of tubing over the south facing slope to connect to the house downspouts; and install approximately 1390 square feet of turf blocks over the existing drain field all within a Critical Dune Area. All work shall be completed in accordance with the attached plans and the terms and conditions of this permit.

**Waterbody Affected: Lake Michigan
Property Location: Ottawa County, Grand Haven Township,
Town/Range/Section 08N/16W/32,
Property Tax No. 70-03-32-331-017**

**EGLE-WRD
WRP015771 v1.0
Approved
Issued On:10/02/2019
Expires On:10/02/2024**

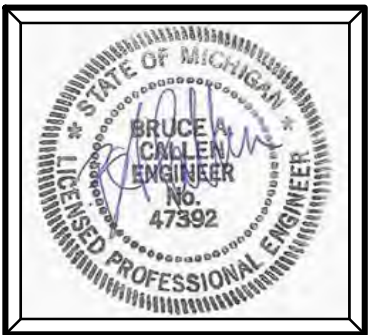
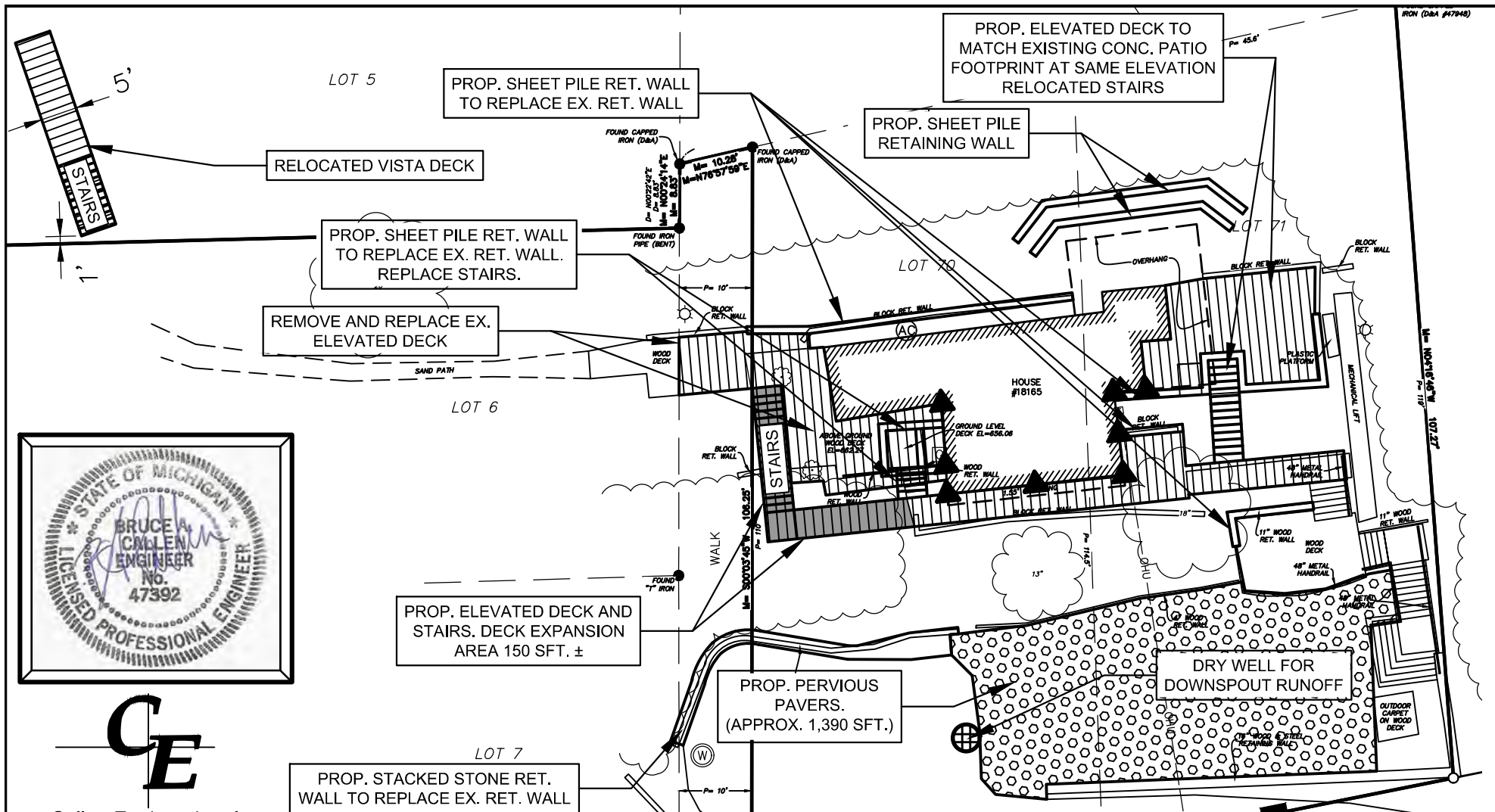

CE
 Callen Engineering, Inc.
 Spring Lake, Michigan

PLANT MATERIAL LIST *				
QTY	KEY	BOTANICAL NAME / COMMON NAME	MIN RQD SIZE*	COMMENTS
	A.b.	Ammophila breviligulata/ American Beach Grass	Culms/plugs	24" SPACING, PLANT AFTER SEPTEMBER 1ST AT ALL DISTURBED AREAS

* ONLY NATIVE PLANT SPECIES SHALL BE USED TO STABILIZE THE SITE.

BRUCE A. CALLEN, P.E.
 I CERTIFY THAT THE PROPOSED IMPROVEMENTS ARE NOT LIKELY TO INCREASE EROSION OR DECREASE STABILITY.

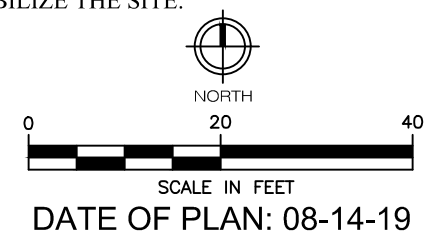

SHEET
CD-2
 SITE PLAN
 Approved

Issued On:10/02/2019
 Expires On:10/02/2024

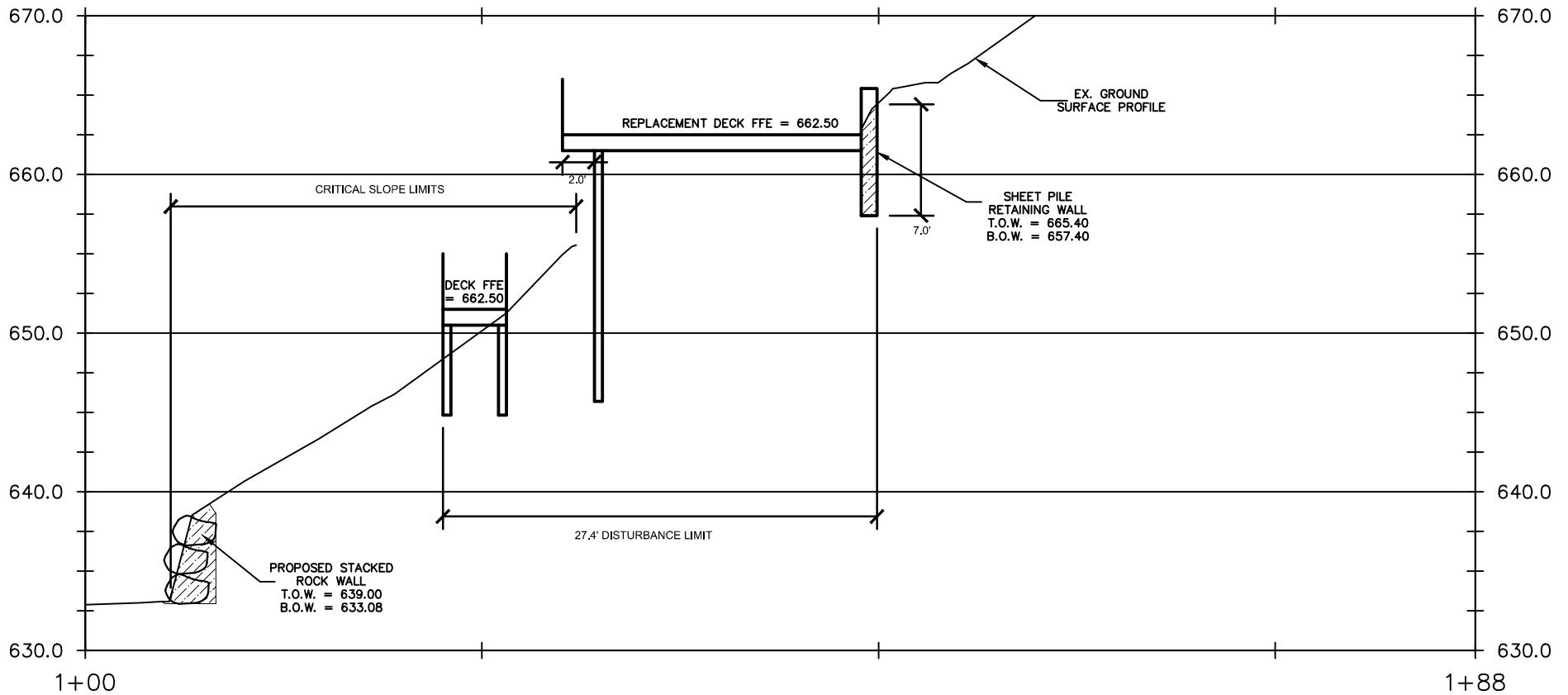

X-SECTION NS 1

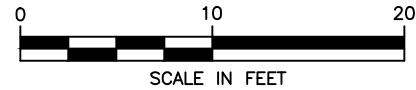

HORIZONTAL SCALE: 1"=10'
 VERTICAL SCALE: 1"=10'

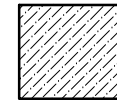

CUT & FILL AREA



Callen Engineering, Inc.
 Spring Lake, Michigan

NOTE:

REPLACEMENT DECKS SHALL BE AT THE SAME LOCATION AND ELEVATION AS THE EXISTING DECKS

SHEET

CD-5

X-SECTIONS

DATE OF PLAN: 07-29-19

Issued On: 10/02/2019

Expires On: 10/02/2024

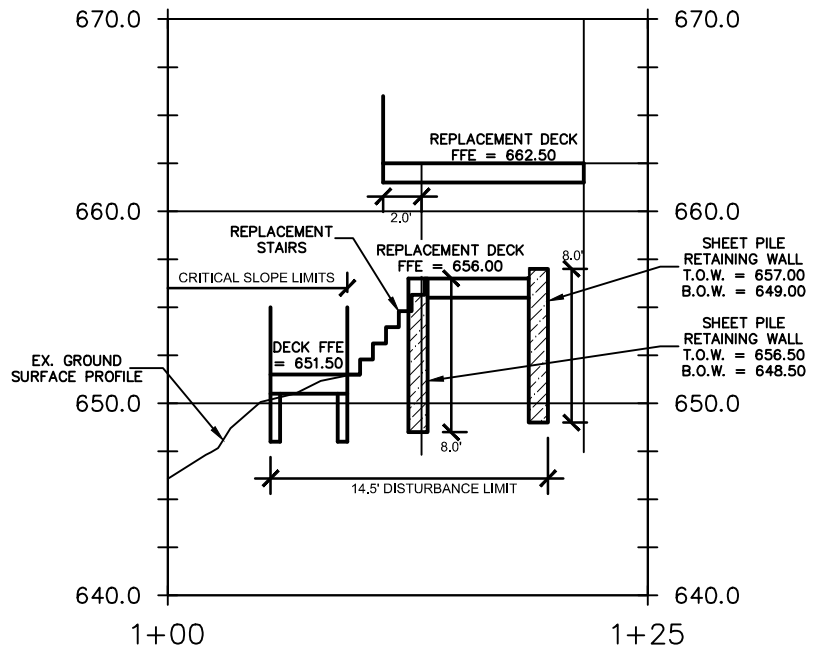

X-SECTION NS 2

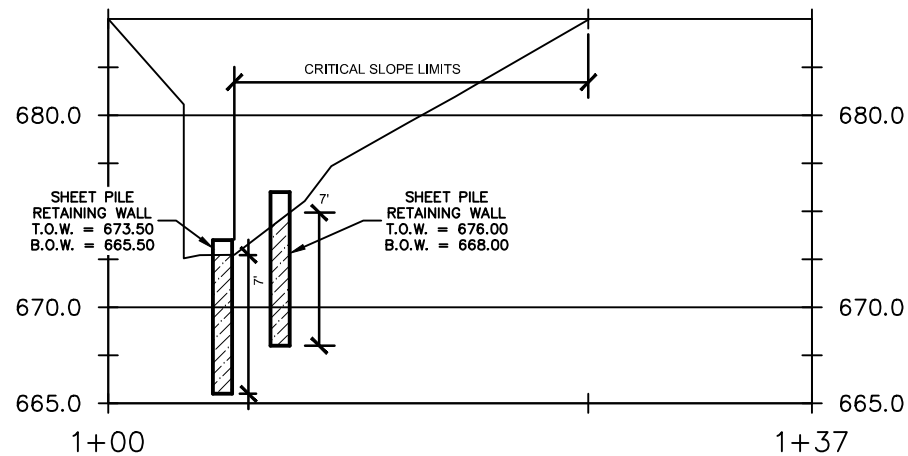

X-SECTION NS 3

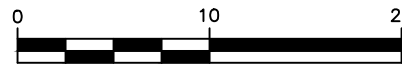

SCALE IN FEET

HORIZONTAL SCALE: 1"=10'
VERTICAL SCALE: 1"=10'

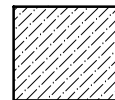

CUT & FILL
AREA

NOTE:

REPLACEMENT DECKS SHALL BE A THE SAME
LOCATION AND ELEVATION AS THE EXISTING DECKS



Callen Engineering, Inc.
Spring Lake, Michigan

SHEET

CD-6

X-SECTIONS

DATE OF PLAN: 07-29-19

Issued On: 10/02/2019

Expires On: 10/02/2024

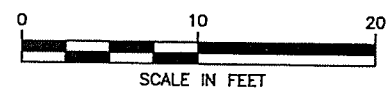
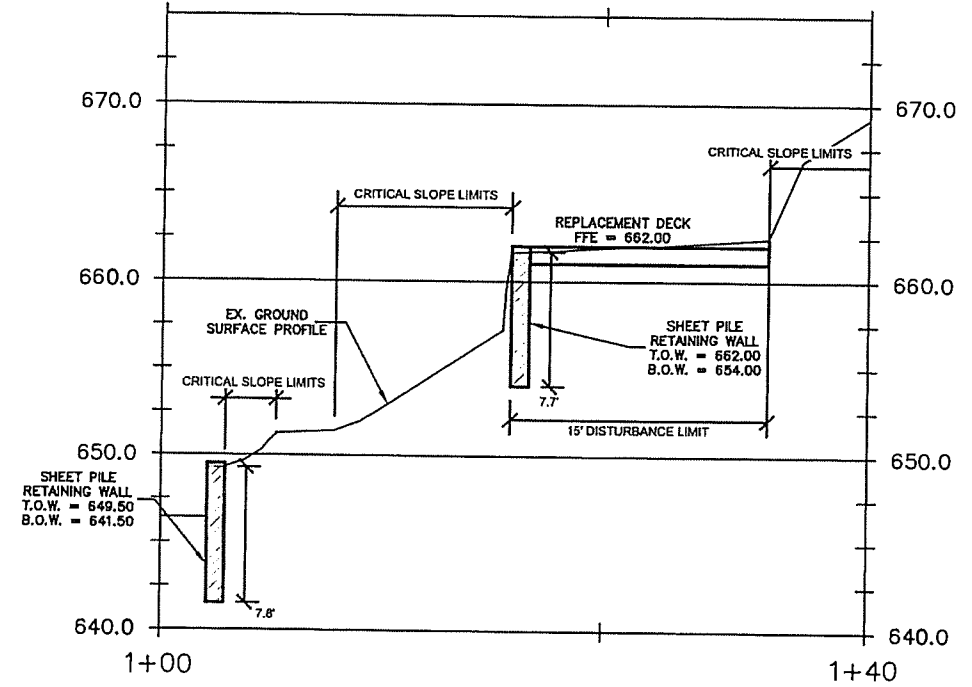
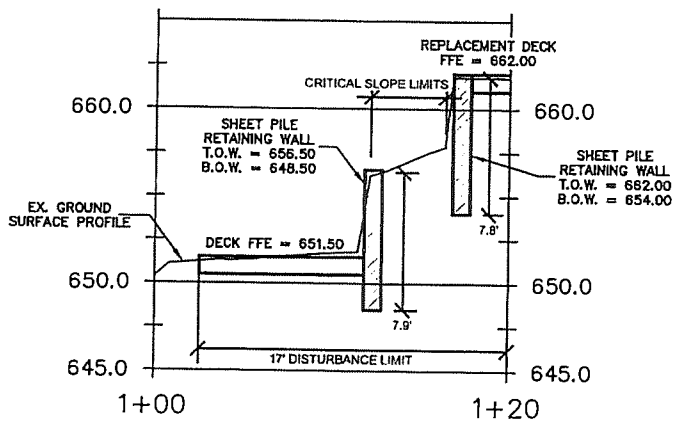

HORIZONTAL SCALE: 1"=10'
VERTICAL SCALE: 1"=10'



NOTE:
REPLACEMENT DECKS SHALL BE AT THE SAME LOCATION AND ELEVATION AS THE EXISTING DECKS

CE
Callen Engineering, Inc.
Spring Lake, Michigan

SHEET
CD-7
X-SECTIONS
DATE OF PLAN: 06-13-19

Handwritten initials and date:
CWA
7/15/19

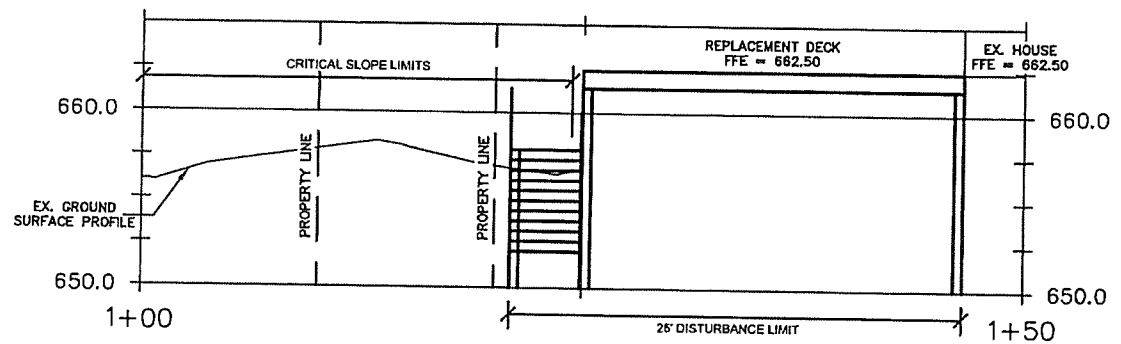

X-SECTION EW

NOTE:
REPLACEMENT DECKS SHALL BE A THE SAME
LOCATION AND ELEVATION AS THE EXISTING DECKS

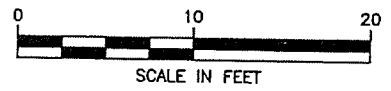

HORIZONTAL SCALE: 1"=10'
VERTICAL SCALE: 1"=10'

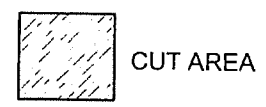

CE
Callen Engineering, Inc.
Spring Lake, Michigan

SHEET
CD-8
X-SECTIONS
DATE OF PLAN: 06-13-19

Handwritten signature and date:
C. Callen
7/15/19



Community Development Memo

DATE: June 22, 2023

TO: Zoning Board of Appeals

FROM: Cassandra Chaphalkar – Associate Planner
Rory Thibault – Senior Planner

RE: 18301 Hillside Drive – Dimensional Variance Application No. 23-03

PARCEL INFORMATION

Owner	Paul & Michele Griffeth
Applicant	Denny Dryer Dryer Architectural Group
Property Address	18301 Hillside Drive
Parcel Number	70-03-32-177-015
Lot Size	5,000 sqft (or 0.11-acres)
Elevation	≈ 20 foot elevation change
Lot Type	Legal Lot of Record
	Exceptionally Small & Narrow
	Critical Dunes
Zoning	R-1 Single Family Residential
Required Setbacks for an Attached Deck	Side - 10 feet
	Rear – 20 feet
Requested Setbacks for an Attached Deck	Side - 7 feet
	Rear – 11 feet, 6 inches



Location Map



Critical Dunes Map

PROPERTY BACKGROUND

ZBA Members may recall previous variance requests for this property. Most recently in 2019, a variance was approved to allow a third story addition, which was not constructed due to increased project costs. Prior to this request, a variance was approved in 2016 to allow an attached garage and an after-the-fact retaining wall.

The property is a legal lot of record and is non-conforming in size and lot width. Because of the non-conforming lot width, the parcel is entitled to a reduction in the minimum side yard setback, which is 10', instead of 15'. Additionally, the parcel is fully encumbered by the Critical Dune Area, which is regulated by EGLE.

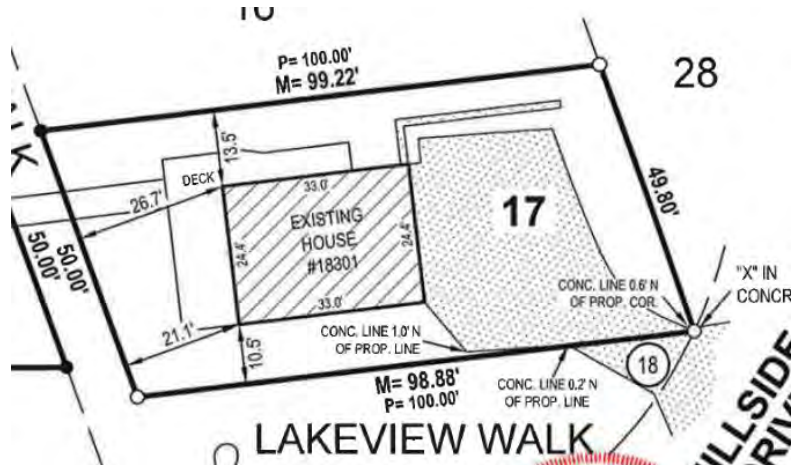

VARIANCE REQUEST

The applicant is seeking a variance to remove and rebuild the existing two story deck **in the same location and footprint**. EGLE regulates construction within the Critical Dune Area, but specifically allows permit exemptions for decks that are being replaced in kind and in place. Because of this exception, it is staff's understanding that no EGLE permit is required for the construction.

Rebuilding the deck will require a variance to be approved for the rear and side yard setbacks. Decks are not permitted to extend into a side yard, requiring a 10' setback, but the applicant is requesting a variance to allow a 7' setback.

Decks are permitted to extend up to 40% of a required rear yard, with a minimum 20' setback. Because the existing house is 21' 1" from the rear lot line, it is reasonable to assume that any deck would require a variance. The applicant is seeking a variance to allow a 11'6" setback where 20' is required.

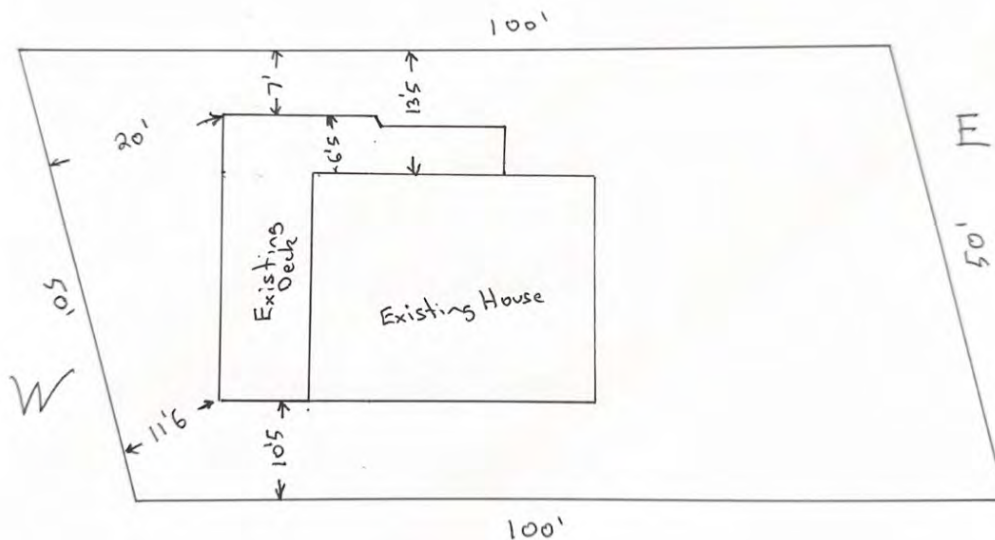

VARIANCE STANDARDS

To authorize a dimensional variance from the strict applications of the provisions of this Ordinance, the ZBA shall apply the following standards and make an affirmative finding as to each of the matters set forth in the standards.

STANDARD 1

There are exceptional or extraordinary circumstances or conditions applying to the property that do not apply generally to other properties in the same zoning classification.

The subject property is within the Critical Dune Area, and has an exceptionally small lot area (*5,000 sqft where 15,000 sqft is required; or 66% smaller in area*). The parcel has steep elevation changes of approximately 20 feet.

The ZBA will need to determine whether this standard is met.

STANDARD 2

The variance is necessary for the preservation and enjoyment of a substantial property right similar to that possessed by other properties in the same zoning district and in the vicinity, provided that possible increased financial return shall not of itself, be deemed sufficient to warrant a variance.

Many properties abutting Lake Michigan have decks to enjoy the view. There are existing doors off the western side of the building that would require a deck or porch to access for egress. The requested variance would authorize construction of a deck equivalent to the structure currently in place.



The ZBA will need to make a determination whether this standard is met given the circumstances of this case.

STANDARD 3

Authorization of such variance will not be of substantial detriment to adjacent property, and will not materially impair the intent and purpose of this Ordinance or the public health, safety, and general welfare of the community.

No correspondence was received for this application (*as of June 22*).

The ZBA will need to make the determination whether this standard is met given the circumstances of this case and the findings on standards 1 and 2.

STANDARD 4

The condition or situation of the specific piece of property or the intended use of said property for which the variance is sought, is not of so general or recurrent a nature as to make reasonably practical the formulation of a general regulation for such condition or situation, a part of this Ordinance.

Legal lots of record are common throughout the Township. Due to the small size of this parcel, there is not an option to increase footprint of the house without increasing the non-conformity.

The ZBA will need to make the determination whether this standard is met.

SAMPLE MOTIONS

If the ZBA determines each standard has been affirmative met, the following motion can be offered:

Motion to conditionally approve a dimensional variance from Section 10.04.C to construct a two-story deck to remain within the existing footprint of the existing deck at 18301 Hillside Drive which will result in a side yard setback of 7-feet and a rear yard setback of 11-feet, 6-inches. Approval of this variance is based upon this Board's findings that all four standards have been affirmatively met.

However, if the ZBA determines each standard has not been affirmatively met, the following motion can be offered:

Motion to deny the dimensional variance from Section 10.04.C to construct a two-story deck to remain within the existing footprint of the existing deck at 18301 Hillside Drive because an alternative exists that does not violate the Grand Haven Charter Township Zoning Ordinance. Denial of this variance is based upon this Board's findings that all four standards have not been affirmatively met.

If the ZBA determines that more information is needed to make an affirmative finding, the following motion can be offered:

Motion to table the dimensional variance application for 18301 Hillside Drive, and direct the applicant and/or staff to provide the following information:

1. *List items.*

Please contact me with questions or concerns.

Narrative:

5/30/23

We are requesting consideration for variances to re-build our existing decking on our home. To our knowledge, the decking was built along with the home, in 1988 (35 years ago). We are the second owners, and when we purchased it 7 years ago, we knew then that the deck would need attention fairly soon. It had been neglected of regular maintenance, and was also beginning to settle.

There is a front and a rear lot to our property. The house is on the front lot, and the rear lot is contiguous with the front. Both lots are only 50 feet wide.

Our decks are not large - approximately 30' x 10'. Neighboring decks are all larger than ours.

The property (parcel) to our north is wooded and undeveloped.

Although we would prefer a slightly larger deck, we are only looking to re-build on the existing footprint that we now have.

We have an upper deck with a lower one directly below the upper, same size and footprint. We would like to re-build both, using composite materials, in order to minimize future maintenance and upkeep.

S

100'

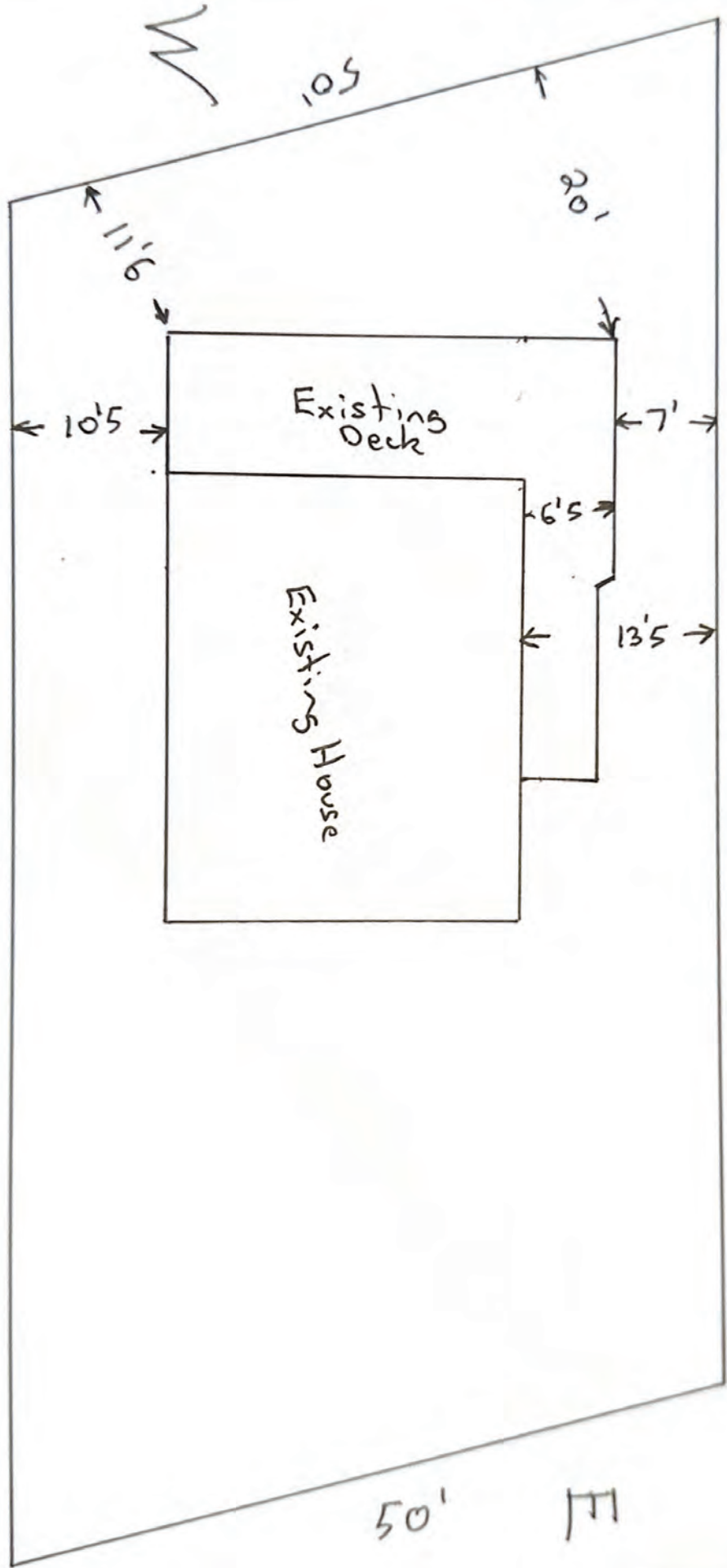

W

50'

20'

11'6"

10'5"

Existing Deck

7'

Existing House

6'5"

13'5"

100'

Scale 3/32

N

50'

E

DESCRIPTION

The Land referred to in this commitment is described as follows:
 Land situated in the Township of Grand Haven, Ottawa County, Michigan, described as:

Lot 20 of an unrecorded plat made by Frank R. Holcomb and wife, being now Lot 20 of "Hendrych's Supervisor's Plat No. 1", according to the plat thereof, as recorded in Liber 8 of Plats on Page 75; on the South half of Northwest fractional quarter of Section 32, Town 8 North, Range 16 West, said Lot being 50 feet wide and approximately 100 feet in depth, and more particularly described as follows: Commencing 942 feet West of the Central quarter post, Section 32, Town 8 North, Range 16 West, thence North 20 degrees West 1036 feet for place of beginning, thence North 20 degrees West 50 feet, thence South 89 degrees 45 minutes East 50 feet, thence South 20 degrees West 100 feet, thence North 89 degrees 45 minutes East to place of beginning.

ALSO, Lot 17 and the Easterly 14.5 feet of the Westerly 28.5 feet of Lot 13 of "Holcomb Hills Subdivision" of the South half of the Northwest fractional quarter and the South half of the Southwest quarter of Section 32, Town 8 North, Range 16 West, Grand Haven Township, Ottawa County, Michigan, according to the plat thereof, as recorded in Liber 8 of Plats Page 46.

70-03-32-176-004 AND 70-03-32-177-015

(Sun Title Commitment No. AHRP96502, dated September 4, 2015)

Note:
 This survey is based upon lot 20 of Hendrych's Supervisor's Plat No. 1 and Lots 17 and 13 of Holcomb Hills Subdivision as recorded in county records.

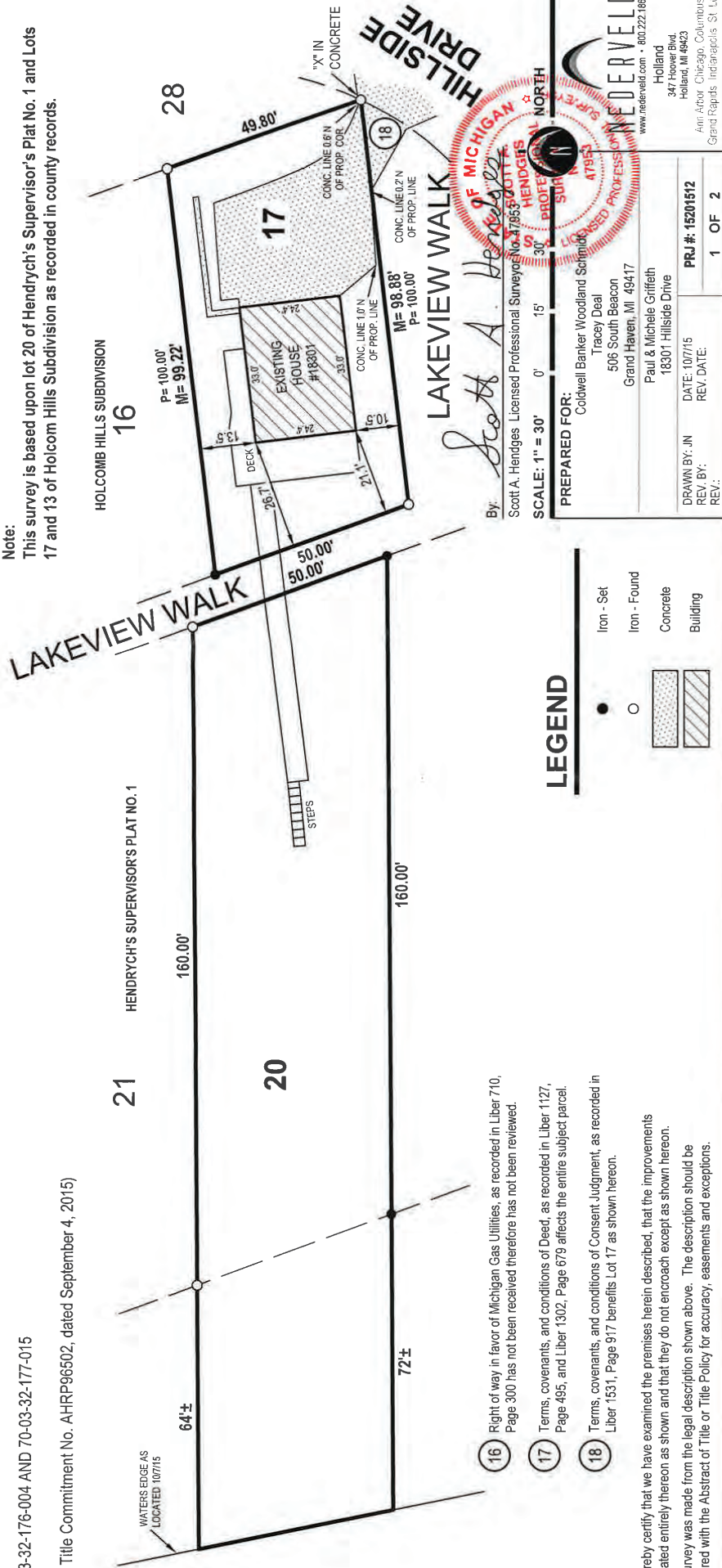

LEGEND

- Iron - Set
- Iron - Found
- ▨ Concrete
- ▨ Building

- 16 Right of way in favor of Michigan Gas Utilities, as recorded in Liber 710, Page 300 has not been received therefore has not been reviewed.
- 17 Terms, covenants, and conditions of Deed, as recorded in Liber 1127, Page 495, and Liber 1302, Page 679 affects the entire subject parcel.
- 18 Terms, covenants, and conditions of Consent Judgment, as recorded in Liber 1531, Page 977 benefits Lot 17 as shown hereon.

We hereby certify that we have examined the premises herein described, that the improvements are located entirely thereon as shown and that they do not encroach except as shown hereon. This survey was made from the legal description shown above. The description should be compared with the Abstract of Title or Title Policy for accuracy, easements and exceptions.

By: *Scott A. Hendrych*
 Scott A. Hendrych Licensed Professional Surveyor No. 17055
 SCALE: 1" = 30' 0' 15' 30'

PREPARED FOR:
 Coldwell Banker Woodland Schmidt
 Tracey Deal
 506 South Beacon
 Grand Haven, MI 49417
 Paul & Michele Griffith
 18301 Hillside Drive

www.mederfeld.com • 800.222.1689
 Holland
 347 Howe Blvd
 Holland, MI 49423
 Ann Arbor Chicago Columbus
 Grand Rapids Indianapolis St. Louis

DATE: 10/7/15
 REV. DATE:
 PRJ #: 15201512
 1 OF 2

Community Development Memo

DATE: May 19, 2022

TO: Zoning Board of Appeals

FROM: Rory Thibault – Senior Planner

RE: 17318 Timber Dunes Drive – Dimensional Variance Application No. 22-01

PARCEL INFORMATION

Owner	Gregory Westra
Property Address	17318 Timber Dunes Drive
Parcel Number	70-07-16-346-007
Lot Size	~20,000 sqft (or 0.46-acres)
Elevation	Topography change of ~12'
Lot Type	Typical Lot
Zoning	R-1 Single Family Residential
Required Setbacks for Decks	Rear – 20 feet
	Side – 15 feet
Requested Setbacks for Decks	Rear – 2-feet
	Side – 13-feet 7-inches



BACKGROUND

On May 24th, 2022 the ZBA held a hearing regarding the Westra variance application for a deck. The matter was approved to replace a deck at 17318 Timber Dunes Drive. Resulting in the following setbacks:

1. West deck edge – side yard setback of 13-feet 7-inches; and
2. South deck edge – rear yard setback of 2-feet.

Following the approval by the ZBA, the permit for the variance was issued on May 31, 2022. The decision of the ZBA permitting the erection of a structure is valid for no longer than one year, unless a zoning permit for the alteration of the structure is obtained, work is started and it proceeds to completion. The ZBA may grant an extension if the applicant demonstrates that the delay was not caused by their action or negligence.

The applicant had corresponded with Staff as of May 10, 2023 recognizing the timeline by which his contractor must submit an application to be reviewed and approved for the construction of the deck according to the approved variance. The Community Development Department received the applicant's deck permit on May 30, 2023.

REASON FOR ZBA EXTENSION

The applicant provides the following reasons for the extension request:

- *Zoning variance (Permit No. P22ZBA0001) was issued on May 31, 2022*
- *By the time the permit was issued, the deck contractor had committed to other jobs until the Fall.*
- *Supply chain issues in late Summer delayed deck product procurement until September.*
- *The deck contractor was seriously injured just before his planned submission of the deck permit application in September, 2022.*
- *The deck contractor had to undergo several procedures to correct complications with his broken leg.*
- *Five months of winter prevented any work on deck. During this time, the deck contractor was assuring us his physical therapy/healing would allow him to start the deck construction in the Spring of 2023.*
- *When the deck contractor was contacted in early April to remind him of the deck permit application submission and zoning variance deadline of May 31, 2023. One week later, he informed us that he was backing out of the project.*
- *A new deck contractor was found in May and his deck permit application was submitted to the Township on May 22, 2023.*



SAMPLE MOTIONS

If the ZBA determines that the delay in obtaining building permits was not caused by the action or the negligence of the applicant, the following motion can be offered:

Motion to approve an extension of 1-year for permit No. P22ZBA0001 regarding a dimensional variance to replace a deck at 17318 Timber Dunes Drive.

However, if the ZBA determines that the delay in obtaining building permits was caused by the action or the negligence of the applicant, the following motion can be offered:

Motion to deny an extension for permit No. P22ZBA0001 regarding a dimensional variance to replace a deck at 17318 Timber Dunes Drive. Denial of this variance is based upon this Board's findings that the standard has not been met.

Please contact me if this raises questions.

SPECIAL MEETING MINUTES
GRAND HAVEN CHARTER TOWNSHIP
ZONING BOARD OF APPEALS
MAY 24, 2022

I. CALL TO ORDER

The special meeting of the Grand Haven Charter Township Zoning Board of Appeals was called to order at 7:00 p.m. by Chair Voss.

II. ROLL CALL

Board of Appeals members present: Voss, Slater, Loftis, Hesselsweet, Egedy-Bader
Board of Appeals members absent: Behm

Also present: Senior Planner Thibault, Manager Cargo

Without objection, Thibault was instructed to record the minutes for the meeting.

III. APPROVAL OF MINUTES

Without objection, the minutes of the May 5, 2022 ZBA Meeting were approved.

Chair Voss noted the amended agenda, changing the order of the new business applications.

Without objection, the amended agenda was approved.

IV. NEW BUSINESS

A. ZBA Variance Application No. 22-01 – Westra – Dimensional Variance

Party Requesting Variance:	Gregory Westra
Address:	17318 Timber Dunes Dr, Grand Haven
Parcel Number:	70-07-16-346-007
Location:	17318 Timber Dunes Dr.

The applicant is seeking to replace an existing deck which would result in a rear yard setback of 2-feet where 20-feet is required and a side yard setback of 13-feet, 7-inches where 15-feet is required. The deck violates Sections 10.01.C.3, 10.01.C.4, and 10.01.C.5 of the Zoning Ordinance.

Thibault provided an overview through a memorandum dated May 19.

The applicant, Mr. Westra, was present to provide information.

- The intent is to replace the current wood deck and railing in kind with composite material
- The pool does not need additional support and will remain in place

The Board discussed the application and noted the following:

- The application and background of the project is familiar due to this being the second review

Standard No. 1 – Exceptional or extraordinary circumstances:

- The property is a typical lot. There are elevation changes on the property of about 12±-feet. The existing deck is legally non-conforming.

Ayes: Voss, Slater, Loftis, Hesselsweet, Egedy-Bader

Nays:

Absent: Behm

Standard No. 2 – Substantial property right:

- Property owners are entitled to build decks. The proposed deck would provide the applicant the continued ability to utilize the deck and pool area as he purchased it originally.
- The backyard is limited in size due to the legally non-conforming house

Ayes: Voss, Slater, Loftis, Hesselsweet, Egedy-Bader

Nays:

Absent: Behm

Standard No. 3 – Will not be a substantial detriment to adjacent parcels, or material impact on the intent and purpose of the Ordinance:

- No letters of opposition were received for this application (*as of May 19th*).

Ayes: Voss, Slater, Loftis, Hesselsweet, Egedy-Bader

Nays:

Absent: Behm

Standard No. 4 – Request is not of such a recurrent nature as to make reasonably practical the formulation of a general regulation:

- There are many houses in the Township that have legally non-conforming deck locations.

Ayes: Voss, Slater, Loftis, Hesselsweet, Egedy-Bader

Nays:

Absent: Behm

Motion by Slater, supported by Loftis, to approve a dimensional variance from Section 14.13.C to replace a deck at 17318 Timber Dunes Drive. Resulting in the following setbacks:

1. West deck edge – side yard setback of 13-feet 7-inches; and
2. South deck edge – rear yard setback of 2-feet.

Approval of this variance is based upon this Board’s findings that all four standards have been affirmatively met.

Which motion carried unanimously, as indicated by the following roll call vote:

Ayes: Voss, Slater, Loftis, Hesselsweet, Egedy-Bader

Nays:

Absent: Behm

B. ZBA Variance Application No. 22-05 – Jacobson – Dimensional Variance

Party Requesting Variance:	Dennis Dryer
Address:	220 ½ Washington, Grand Haven
Parcel Number:	70-07-08-200-006
Location:	13467 Windcrest

The applicant is seeking to install a new retaining wall measuring 10-feet 2-inches in height where a maximum height of 8-feet is allowed. The retaining wall would violate Section 14.13.C of the Zoning Ordinance.

Thibault provided an overview through a memorandum dated May 19.

The applicant, Mr. Dryer, was present to provide information.

- The retaining wall will be replaced with concrete members and block/stone material, rather than with the same timber material which is deteriorating
- It is difficult to get a Special Exception from EGLE, which would be required in order to make a series of compliant retaining walls
- The existing layout is dangerous, expanding the driveway would alleviate safety and maneuvering concerns – a railing will also be provided. The wall will extend past grade to form a curb.
- EGLE approval was granted on 06/25/2021
- Trees were cleared during demolition work, but the stumps remain – these will be buried

The Board discussed the application and noted the following:

- Trees were cleared during demolition work, but the stumps remain – these will be buried

Standard No. 1 – Exceptional or extraordinary circumstances:

- The subject property is within the Critical Dune Area, has significant topography changes, and has been reviewed and approved by EGLE.

Ayes: Voss, Slater, Loftis, Hesselsweet, Egedy-Bader

Nays:

Absent: Behm

Standard No. 2 – Substantial property right:

- Property owners of residentially zoned properties are entitled to build a structurally sound driveway on the property.

Ayes: Voss, Slater, Loftis, Hesselsweet, Egedy-Bader

Nays:

Absent: Behm

Standard No. 3 – Will not be a substantial detriment to adjacent parcels, or material impact on the intent and purpose of the Ordinance:

- No correspondence was received for this application (*as of May 19th*). The property is located within a gated community with driveway access not open to the public.

Ayes: Voss, Slater, Loftis, Hesselsweet, Egedy-Bader

Nays:

Absent: Behm

Standard No. 4 – Request is not of such a recurrent nature as to make reasonably practical the formulation of a general regulation:

- The combination of the topographic change and location within the Critical Dune Area limit the buildable area. There is no possible retaining wall that could be created that would not need to be approved by EGLE. The more conforming solution of a separated series of independent retaining walls would greater impact the dune than the proposed and approved design as shown.

Ayes: Voss, Slater, Loftis, Hesselsweet, Egedy-Bader

Nays:

Absent: Behm

Motion by Loftis, supported by Slater, to **approve** a dimensional variance from Section 14.13.C to build a new 18 linear foot retaining wall at 13467 Windcrest Ln. that will result in a height of 10 feet 2 inches. Approval of this variance is based upon this Board's findings that all four standards have been affirmatively met.

Which motion carried unanimously, as indicated by the following roll call vote:

Ayes: Voss, Slater, Loftis, Hesselsweet, Egedy-Bader

Nays:

Absent: Behm

C. ZBA Variance Application No. 22-06 – Huddas – Dimensional Variance

Party Requesting Variance: Green Shield Home
Address: 14939 Mercury Dr, Grand Haven
Parcel Number: 70-07-01-130-011
Location: 14939 Mercury Dr, Grand Haven

The applicant is seeking to replace a deck located within the required side yard which would result in a side yard setback of 9-feet, 10-inches, where 11-feet is required. The deck violates Section 10.04.C.4 of the Zoning Ordinance.

Thibault provided an overview through a memorandum dated May 19.

The applicant, Mr. Rought, was present to provide information.

- Expressed that shrinking the deck to a compliant size would create a safety hazard in the side yard as a gap between the deck and retaining wall would be created
- Confirmed that the deck would be extending 6’ closer to the river

The Board discussed the application and noted the following:

- Noted that this would be increasing the side yard setback to 9’ - 10” from the current nonconforming setback of 9’ for the retaining wall which was granted last year.

Standard No. 1 – Exceptional or extraordinary circumstances:

- The subject property is located on a segment of the Grand River where a 18-foot elevation change exists between Mercury Drive and the water. The lot is legally nonconforming in regards to lot width.

Ayes: Voss, Slater, Loftis, Hesselsweet, Egedy-Bader
Nays:
Absent: Behm

Standard No. 2 – Substantial property right:

- It is common for property owners with river frontage to have a deck overlooking the water.

Ayes: Voss, Slater, Loftis, Hesselsweet, Egedy-Bader
Nays:
Absent: Behm

Standard No. 3 – Will not be a substantial detriment to adjacent parcels, or material impact on the intent and purpose of the Ordinance:

- No correspondence was received for this application (*as of May 19th*).

Ayes: Voss, Slater, Loftis, Hesselsweet, Egedy-Bader
Nays:

Absent: Behm

Standard No. 4 – Request is not of such a recurrent nature as to make reasonably practical the formulation of a general regulation:

- The combination of a narrow lot and elevation change are unique. There may be properties with similar circumstances in the same vicinity but they are limited in number and each property would need to be reviewed to determine if a variance is applicable.

Ayes: Voss, Slater, Loftis, Hesselsweet, Egedy-Bader

Nays:

Absent: Behm

Motion by Hesselsweet, supported by Loftis, to **approve** a dimensional variance from Section 10.04.C.4 to replace an existing deck with a new deck resulting in a side yard setback of 9-feet, 10-inches at 14939 Mercury Drive.

Approval of this variance is based upon this Board’s findings that all four standards have been affirmatively met.

Which motion carried unanimously, as indicated by the following roll call vote:

Ayes: Voss, Slater, Loftis, Hesselsweet, Egedy-Bader

Nays:

Absent: Behm

D. ZBA Variance Application No. 22-04 – Skeels – Dimensional Variance

Party Requesting Variance:	Gary & Jane Skeels
Address:	14494 Angelus Cir., Grand Haven
Parcel Number:	70-03-35-351-022
Location:	14494 Angelus Cir., Grand Haven

The applicant is seeking a variance for a 10’ x 16’ shed located in the front yard, which is in violation of Section 10.01.C.11.a of the Zoning Ordinance that prohibits accessory structures within the front yard.

Thibault provided an overview through a memorandum dated May 19.

The applicant, Mr. Skeels, was present to provide information.

- The accessory structure is not complete, rather it is “dried in” to protect the material
- Confirmed there are overhead utilities located in the front yard (water side) and underground utilities and a septic system in the rear yard (road side)
- Stated that there would not be enough space in either side yard for the accessory structure to be located

- Interested in building a garage for additional storage space in the future

The Board discussed the application and noted the following:

- A variance or Special Land Use would likely be needed if the proposed future garage as shown on the plan were to be built
- Noted that the rear yard is constrained in finding any compliant location
- Staff clarified that there are no view-shed triangle requirements in the current Zoning Ordinance
- Staff noted there is a compliant solution through a Special Land Use

Motion by Slater, supported by Hesselsweet, to **postpone** consideration of the dimensional variance application for 14494 Angelus Circle, until the applicant does the following:

1. Refer the application to the Planning Commission since there is another compliant option available, by submitting a Special Land Use application for an accessory structure located in the front yard per Section 12.07 of the Zoning Ordinance

Which motion carried unanimously, as indicated by the following roll call vote:

Ayes: Voss, Slater, Loftis, Hesselsweet, Egedy-Bader

Nays:

Absent: Behm

V. REPORTS

Thibault provided an update on the Grand Rapids Water Treatment Plant Solar Installation

VI. EXTENDED PUBLIC COMMENTS – None

VII. ADJOURNMENT

Without objection, the meeting was adjourned at 8:11pm

Respectfully submitted,



Rory Thibault

Acting Recording Secretary

From: [Gregory Westra](#)
To: [Rory Thibault](#)
Cc: [Cassandra Chaphalkar](#)
Subject: Permit No. P22ZBA0001 Extension Request - 17318 Timber Dune Drive
Date: Tuesday, May 30, 2023 11:24:34 AM

Rory,

Despite my best efforts to move our deck project along with our deck contractors, the window for the zoning variance for the deck replacement has come to a close. My current deck contractor has submitted his deck permit to the township for review. Here are the many reasons the deck reconstruction was not completed within the one year window as defined by the zoning variance.

- Zoning variance (Permit No. P22ZBA0001) was issued on May 31, 2022
- By the time the permit was issued, the deck contractor had committed to other jobs until the Fall.
- Supply chain issues in late Summer delayed deck product procurement until September.
- The deck contractor was seriously injured just before his planned submission of the deck permit application in September, 2022.
- The deck contractor had to undergo several procedures to correct complications with his broken leg.
- Five months of winter prevented any work on deck. During this time, the deck contractor was assuring us his physical therapy/healing would allow him to start the deck construction in the Spring of 2023.
- When the deck contractor was contacted in early April to remind him of the deck permit application submission and zoning variance deadline of May 31, 2023. One week later, he informed us that he was backing out of the project.
- A new deck contractor was found in May and his deck permit application was submitted to the Township on May 22, 2023.

Given that these delays and setbacks were beyond my control, I would like to request an extension be granted to zoning variance P22VBA0001 so that the deck replacement can be completed this summer.

Sincerely,

Gregory Westra
17318 Timber Dunes Dr, Grand Haven, MI 49417
(616) 847-1098 gregorydavidwestra@gmail.com

From: [Gregory Westra](#)
To: [Rory Thibault](#)
Subject: Re: ZBA Hearing - 17318 Timber Dune Drive
Date: Friday, May 12, 2023 10:18:11 AM
Attachments: [image001.png](#)

Rory,

Supply chain issues related to our choice of materials for the project delayed starting during the summer months of 2022. The builder who was going to build the deck and apply for the application, fell off a roof in the fall of 2022 and was in the hospital for 2 months and was still in rehab up to a month ago, that is why the deck permit application has not yet been submitted. We have just changed to a new builder, as the one who was hurt is not able to build it now. The new builder has been notified of the pressing need to submit his deck construction permit and commence construction prior to the expiration date of May 31, 2023.

Thank you,
Gregory Westra
17318 Timber Dunes Dr, Grand Haven, MI 49417
gregorydavidwestra@gmail.com 616-847-1098

On Wed, May 10, 2023 at 11:10 AM Rory Thibault <rthibault@ght.org> wrote:

Good morning Mr. Westra,

Thank you for your inquiry with regard to an extension of your variance that was issued on 05/31/22.

No decision of the Zoning Board of Appeals permitting the erection of a structure shall be valid for a period longer than one (1) year, unless a zoning permit for such erection or alteration is obtained within such year and such erection or alteration is started and proceeds to completion in accordance with the terms of such permit.

- We have not received a permit application for the construction of the deck.
- Please have your contractor submit a [deck application](#) with all the required documentation for Township Staff to review.
- If the documents cannot be submitted, reviewed, approved, and have work commence prior to the expiration of the Zoning Variance permit the ZBA may grant an extension of the variance, provided the applicant demonstrates that the delay in obtaining building permits was not caused by the action or negligence of the applicant to the satisfaction of the Board.

Please let me know if you have any questions.

Sincerely,



GRAND HAVEN CHARTER TOWNSHIP

Rory Thibault, Senior Planner

Phone: 616-604-6319

Email: rthibault@ght.org **Web:** www.ght.org

13300 168th Avenue, Grand Haven, MI 49417

From: Rory Thibault

Sent: Monday, May 23, 2022 11:25 AM

To: Gregory Westra <gregorydavidwestra@gmail.com>; Cassandra Hoisington <choisington@ght.org>

Subject: RE: ZBA Hearing - 17318 Timber Dune Drive

Good morning Mr. Westra,

Yes, apologies for the delay.

Please see attached for the agenda and memo Staff has prepared.

Sincerely,

Rory Thibault

Senior Planner at Grand Haven Charter Township

Phone 616-604-6319

Web www.gh.org **Email** rthibault@gh.org

13300 168th Avenue, Grand Haven, MI 49417

From: Gregory Westra <gregorydavidwestra@gmail.com>
Sent: Monday, May 23, 2022 10:58 AM
To: Cassandra Hoisington <choisington@gh.org>
Cc: Rory Thibault <rthibault@gh.org>
Subject: ZBA Hearing - 17318 Timber Dune Drive

Cassandra,

Will the scheduled May ZBA hearing for my zoning variance application be held tomorrow at 7:00 PM? I haven't heard anything since our last meeting in early April.

Gregory Westra

17318 Timber Dunes Dr, Grand Haven, MI 49417

(616) 847-1098 gregorydavidwestra@gmail.com

RECEIVED

Grand Haven Charter Township

MAY 30 2023

13300 168th Avenue, Grand Haven, MI 49417

Phone: (616) 842-5988 | Fax: (616) 842-9419 | building@ght.org



FWD BLDG: _____

Residential Deck

Separate Applications Must be Completed for Plumbing, Mechanical, or Electrical Work Permits

Decks, Accessory Buildings and Basement Finishes are eligible for both regular and limited plan permits

See the "From Application to Completion" section of the attached guide for details

I. Owner/ Job Location <input type="checkbox"/> Owner is Applicant (if homeowner is applicant, complete Section I and continue to Section V)			
Name of Property Owner Gregory Westra		Home Phone (616) 847-1098	Cell (616) 847-1098
Address 17318 Timber Dune Drive		City Grand Haven	State Michigan
Job Location (if different than above)		Zip 49417-8835	
Parcel # 70-07-16-346-007		Name of City, Village, or Township Job is located <input type="checkbox"/> City <input type="checkbox"/> Village <input checked="" type="checkbox"/> Township of : Grand Haven Township	
		Email (REQUIRED) gregorydavidwestra@gmail.com	
II. Builder/Contractor/Licensee Information			
Company Name DVS Construction LLC		Company Address 5208 Nattes Way	
Business Phone		Cell 616 291 6247	Fax
Email (REQUIRED) dustin@dvsconstructionllc.com			
Licensee Name DVS Construction LLC		State Builder's License # 2102197852	Expiration Date 5/31/28
Federal ID # (or reason for exemption) N/A No Employees		Workers Comp (or reason for exemption) N/A No Employees	UIA Employer # (or reason for exemption)
III. Architect or Engineer			
Name		Address	
City	State	Zip	Business Phone
Email	State Architect or Engineering License #		Expiration Date
IV. Builder's Affidavit			
Section 23a of the State Construction Code Act of 1972, 1972 PA 230, MCL 125.1523A, prohibits a person from conspiring to circumvent the licensing requirements of this state relating to persons who are to perform work on a residential building or a residential structure. Violators of Section 23a are subject to civil fines. I hereby certify that the proposed building work is authorized by the owner of record and that I have been authorizing by the owner to make this application as his/her authorized agent, and we agree to conform to all applicable laws of the State of Michigan. All information submitted on this application is accurate to the best of my knowledge.			
Signature of Licensee 		Print Name of Licensee Dustin Vander Wijs	Date 5/30/23
V. Homeowner Affidavit			
I hereby certify the work described in this permit application shall be done by myself on my own dwelling in which I am living, or about to occupy. All work shall be done in accordance with the codes and shall not be backfilled, enclosed, dry walled, covered-up, or used until it has been inspected or approved by the appropriate inspector. I understand my responsibility to arrange for the required inspections and I agree not to move anything into, or use the building in any way, until I have received written approval to do so from the appropriate inspector. I understand that for any such affidavit connected to a building permit, I (or appropriate licensed contractors) am required to obtain additional permits before installing any electrical, plumbing, heating, air conditioning, fireplace, wood stove, ventilation component, or other similar work. I understand all of the above and acknowledge that failure to comply with the above requirements may cause revocation of the building permit and/or legal action to be taken against me.			
Signature of Homeowner		Print Name of Homeowner	Date

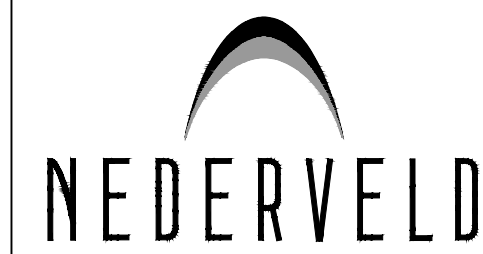

www.nederveld.com
800.222.1868
HOLLAND
347 Hoover Blvd.
Holland, MI 49423
Phone: 616.393.0449

ANN ARBOR
CHICAGO
COLUMBUS
GRAND RAPIDS
INDIANAPOLIS
ST. LOUIS

PREPARED FOR:
Greg Westra

17318 Timber Dunes Drive
Grand Haven, MI 49417

CREATED:

Drawn: KV Date: 2/9/22

REVISIONS:

Rev: _____ Date: _____
Drawn: _____

17318 Timber Dunes Drive

Topographic Survey

17318 Timber Dunes Drive
PART OF THE SOUTH 1/2 OF SECTION 16, T7N, R18W
GRAND HAVEN TOWNSHIP, OTTAWA COUNTY, MICHIGAN

STAMP:



PROJECT NO:
22200131

SHEET NO:
TO

SHEET: 1 OF 1

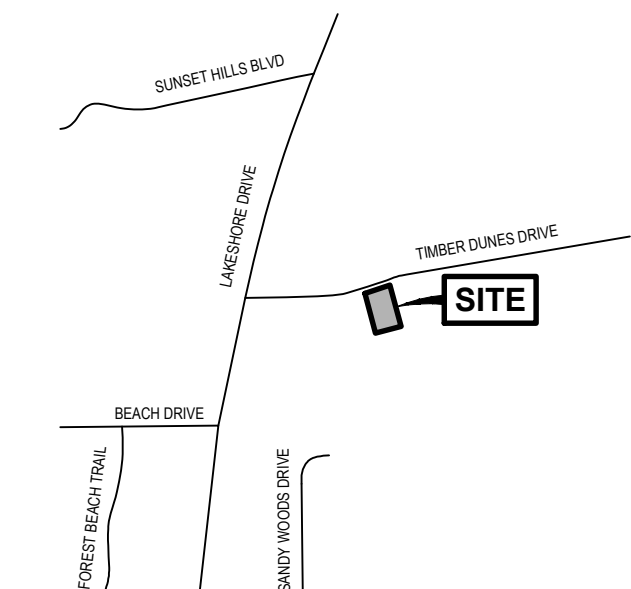

LOCATION MAP

NOT TO SCALE



TITLE INFORMATION

Warranty Deed recorded in Liber 1500, Page 281, dated July 23, 1991, Ottawa County Register of Deeds Office

TITLE DESCRIPTION

The following described premises situated in The Township of Grand Haven, County of Ottawa, and State of Michigan to wit:

Parcel 1: Lot 4, Timber Dunes Subdivision, as recorded in Liber 17 of Plats on Page 65.

SURVEYOR'S NOTES

- 1) Flood Zone Classification: An examination of the National Flood Insurance Program's Flood Insurance Rate Map for Community Number 260270, Panel Number 0180, with an Effective Date of 10/21/21, shows this parcel to be located in Zone X (subject to map scale uncertainty). No field surveying was performed to determine this zone.
- 2) Source information from plans and markings has been combined with observed evidence of utilities to develop a view of the underground utilities. However, lacking excavation, the exact location of underground features cannot be accurately, completely, and reliably depicted. In addition, in some jurisdictions, §11 or other similar utility locate requests from surveyors may be ignored or result in an incomplete response. Where additional or more detailed information is required, the client is advised that excavation may be necessary.
- 3) NOTE TO CONTRACTORS: 3 (THREE) WORKING DAYS BEFORE YOU DIG, CALL MISS DIG AT TOLL FREE 1-800-482-7171 FOR UTILITY LOCATIONS ON THE GROUND.

BENCHMARKS

BENCHMARK #5000 ELEV. = 628.76 (NGVD88)
Set benchmark on top flange bolt located under "E" of "ELIWI", +/- 1' above ground level. Located +/- 9' North of the Northerly edge of bit of Timber Dunes Drive & +/- 15' West of the Easterly property line extended.

BENCHMARK #5300 ELEV. = 642.08 (NGVD88)
Found benchmark on NW side of 6" Pine tree located +/- on line with Easterly property line extended & +/- 9' South of Southeast property corner.

LEGEND

- AC Air Conditioner
- △ Benchmark / Control Point
- EM Electric Meter
- GM Gas Meter
- Iron - Set
- Iron - Found
- ☼ Light Pole
- x - x - Fence
- Tree symbol Tree
- Asphalt symbol Asphalt
- Concrete symbol Concrete
- Existing Building symbol Existing Building

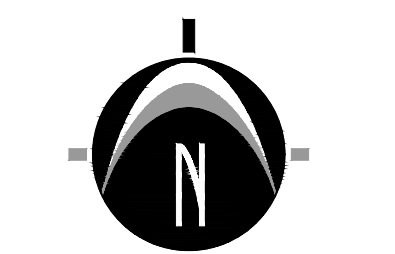

0' 5' 10' 20'
SCALE: 1" = 10'



UTILITY LOCATIONS ARE DERIVED FROM ACTUAL MEASUREMENTS OR AVAILABLE RECORDS. THEY SHOULD NOT BE INTERPRETED TO BE EXACT LOCATIONS NOR SHOULD IT BE ASSUMED THAT THEY ARE THE ONLY UTILITIES IN THIS AREA.
NOTE: EXISTING UTILITIES AND SERVICE LINES IDENTIFIED AS "PLAN" WERE OBTAINED FROM AVAILABLE CITY AS-BUILT RECORD DRAWINGS. THE CONTRACTOR SHALL VERIFY THE LOCATION, DEPTH AND STATUS OF ALL UTILITIES AND SERVICE LINES PRIOR TO NEW CONNECTIONS.

